

[3862]-103**S.E. (Civil) (First Semester) EXAMINATION, 2010****STRENGTH OF MATERIALS****(2008 COURSE)****Time : Three Hours****Maximum Marks : 100**

N.B. :- (i) Answer *three* questions from Section I and *three* questions from Section II.

Answer Q. 1 or Q. 2, Q. 3 or Q. 4 and Q. 5 or Q. 6 from Section I and Q. 7 or Q. 8, Q. 9 or Q. 10 and Q. 11 or Q. 12 from Section II.

(ii) Answers to the two Sections should be written in separate answer-books.

(iii) Neat diagrams must be drawn wherever necessary.

(iv) Figures to the right indicate full marks.

(v) Use of logarithmic tables, slide rule Mollier charts, electronic pocket calculator and steam tables is allowed.

(vi) Assume suitable data, if necessary.

SECTION I

1. (a) Write short notes on : [4]

(i) Factor of safety

(ii) Single and double shear.

(b) Draw and explain stress-strain diagram for mild steel. [5]

(c) A reinforced concrete column of 300 mm diameter is reinforced with 6 bars of 16 mm diameter. Allowable stress in concrete is 7 MPa and allowable stress in steel is 140 MPa. Modular ratio is 13. Find out the load carrying capacity of the column. [8]

Or

2. (a) Write short notes on : [9]

(i) Poisson's ratio

(ii) Bulk modulus

(iii) Modulus of rigidity

(iv) Young's modulus

State relation between any *three* of these.

(b) A steel rod 2 m long is at 30°C. The temperature of this rod is increased to 150°C. Find : [8]

(i) free expansion of the rod

(ii) temperature stress produced if expansion is prevented and nature of stress.

(iii) stress produced if 2 mm expansion is permitted and nature of stress

if $\alpha = 12 \times 10^{-6} / ^\circ\text{C}$ and $E = 200 \text{ GPa}$, Bar diameter = 16 mm.

3. (a) A continuous beam ABCD is simply supported at A and C and is loaded as shown in Fig. 1. Draw SFD, BMD and AFD. Show all important points. [9]

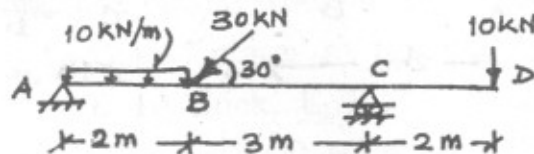

Fig. 1

- (b) Draw loading diagram and BMD from SFD given in Fig. 2. The beam is a simply supported beam supported at A and B. There is no moment applied as loading. [8]

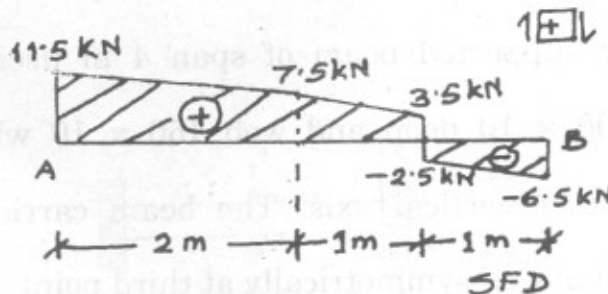

Fig. 2

Or

4. (a) A simply supported beam ABCD is supported and loaded as shown in Fig. 3. Draw SFD and BMD and show all important points. Find out the value and location of maximum bending moment. [9]

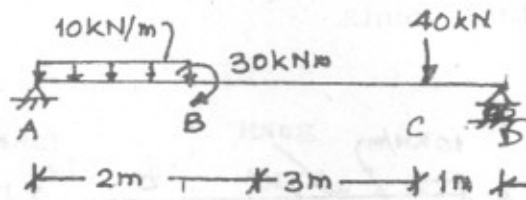

Fig. 3

- (b) Derive expression for shear force and bending moment at a distance 'x' from free end of a cantilever subjected to uniformly varying load with loading intensity 'w', at the fixed end. Span of the cantilever is 'L'. Also draw SFD and BMD for the cantilever. (Loading intensity at the free end is zero) [8]
5. (a) A simply supported beam of span 4 m uses a T section with flange 100×10 deep and web 150×10 wide. The section is symmetric @ vertical axis. The beam carries two point loads 5 kN each placed symmetrically at third point. Find out maximum shear stress in the beam. [8]

- (b) A symmetric I section is 150 wide and 200 deep. The flange thickness and web thickness is 10 mm. This section is used for cantilever beam having a span of 3 m and subjected to uniformly distributed load. Find the maximum u.d.l. that can be supported if $E = 200$ GPa and maximum allowable stress is 180 MPa. [8]

Or

6. (a) Draw shear stress distribution on a T section with flange. 150 × 15 deep and flange 200 × 20 wide. The section is symmetric @ vertical axis. The shear force applied is 110 kN. [8]
- (b) A wooden rectangular section 200 × 300 deep is strengthened by fixing two steel plates at the top and bottom of the section 200 wide and 10 thick. $E_s/E_w = 20$ and allowable stresses in steel and timber are 200 MPa and 20 MPa respectively. Find the moment of resistance of the section. [8]

SECTION II

7. (a) A 75 kW motor is driving a line shaft through gear 'A' at 26.5 r.p.m. Bevel gear at B and C drives cement mixtures. If the power requirement of mixer driven by gear B is 25 kW and that of C is 50 kW, what are the required shaft diameters d_1 and d_2 . If the allowable shearing stress in the shaft is 40 MPa, (Refer Fig. 4). [9]

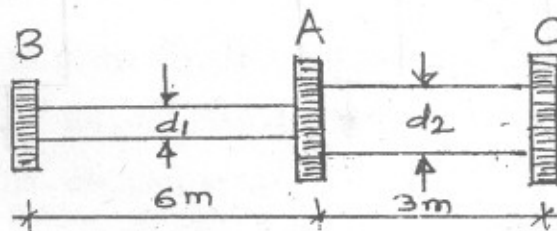

Fig. 4

- (b) Determine the strain energy of the prismatic beam AB, subjected u.d.l. of 25 kN/m over total span AB of 10 m. Assume :

$$I = 195.3 \times 10^3 \text{ mm}^4$$

$$E = 2 \times 10^5 \text{ MPa}$$

The beam AB is simply supported. [8]

Or

8. (a) A steel shaft of 950 mm diameter is required to transmit 220 kW power at 225 r.p.m. and maximum torque is 40% greater than the mean torque. Find the maximum allowable shear stress in the shaft material. [8]

- (b) Three round bars having same length but different shapes are shown in Fig. 5. All three bars are subjected to same load, P. Find the amount of strain energy stored in each bar, assuming linear elastic behaviour. [9]

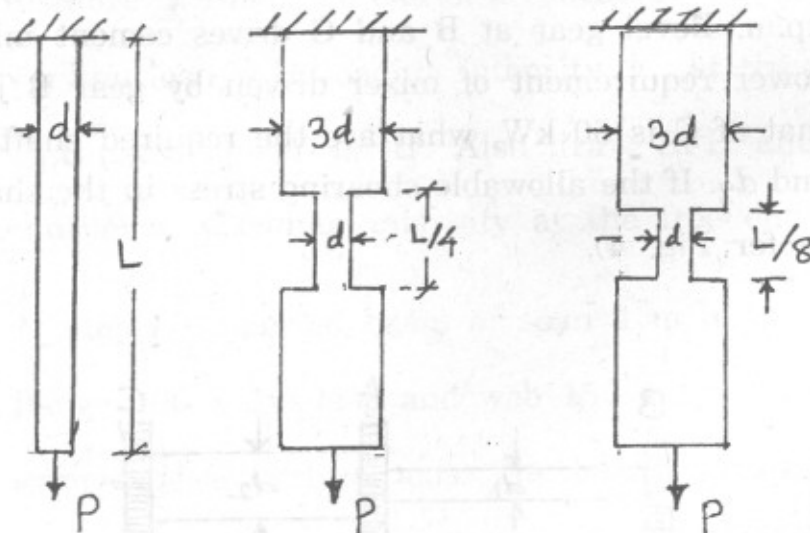

Fig. 5

9. (a) A generator shaft of hollow circular cross-section with outside diameter = 200 mm and inside diameter = 160 mm, is subjected to a torque of 11.1 kNm and axial compressive load of 362 kN. Determine the maximum tensile stress, maximum compressive stress and maximum shear stress in the shaft. [8]
- (b) For the element shown in Fig. 6, locate the planes on which magnitude of the shear stress and normal stress are equal. Show the results on properly oriented elements. Also find the principal stresses. [9]

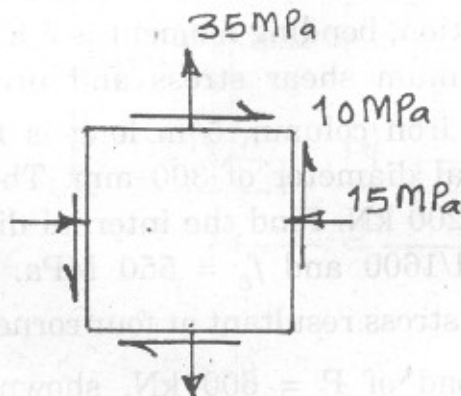

Fig. 6

Or

10. (a) An element in plane stress is subjected to stresses $\sigma_x = -50$ MPa, $\sigma_y = 10$ MPa and $\tau_{xy} = -40$ MPa as shown in Fig. 7, using Mohr's circle, determine : [8]
- (i) Stresses acting on the element rotated through an angle $\theta = 45^\circ$.

(ii) Principal stresses.

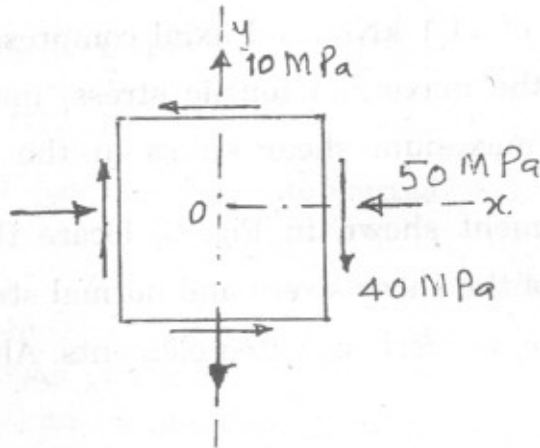

Fig. 7

- (b) A shaft of 100 mm diameter transmits 200 kW power at 200 r.p.m. At a section, bending moment is 5 kNm. Find the principal stresses, maximum shear stress and principal plane. [9]
11. (a) A hollow cast iron column, 5 m long is fixed at both end and has an external diameter of 300 mm. The column supports an axial load of 1200 kN. Find the internal diameter of the column. Assume $\alpha = 1/1600$ and $f_c = 550$ MPa. [8]
- (b) Determine the stress resultant at four corners of column subjected to eccentric load of $P = 600$ kN, shown in Fig. 8. [8]

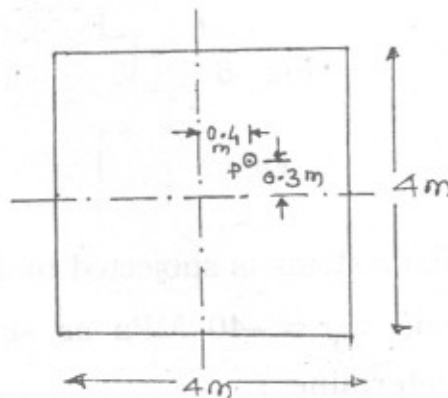

Fig. 8

Or

12. (a) Two identical rolled steel 'I' sections are used to form a built up section for axially loaded column. The sections are placed side by side and connected together suitably to act as a one unit as shown in Fig. 9. [10]

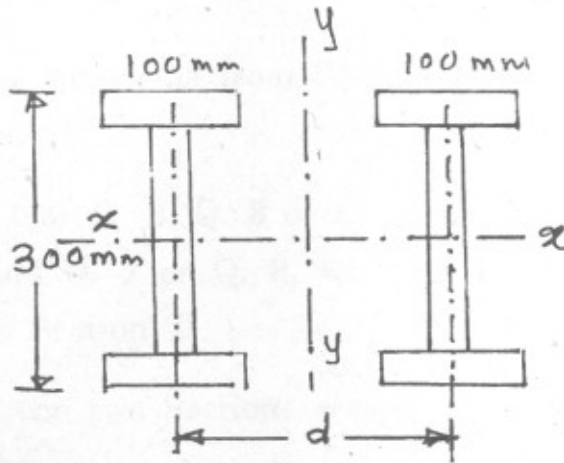

Fig. 9

Calculate the distance, 'd' between these sections for same load carrying capacity about both the axes. Also find safe load using factor of safety of 4. The column has one end hinged and other end fixed, with a height of 4 m.

Use Rankine's formula with $f_c = 320$ MPa, $\alpha = 1/7500$.

Properties of single I section are as follows :

$$\text{Area} = 6133 \text{ mm}^2$$

$$I_{XX} = 98.21 \times 10^6 \text{ mm}^4, K_{XX} = 126.6 \text{ mm}$$

$$I_{YY} = 9.9 \times 10^6 \text{ mm}^4, K_{YY} = 40.2 \text{ mm}$$

- (b) Explain with neat sketches the stable, unstable and neutral equilibrium related to column subjected to axial load and critical load. [6]

